

HoliMaker®

Revolutionizing access to plastic injection molding



The perfect manual injection
molding machine for:

*Prototyping
Material testing
Recycling*

At HoliMaker, we are rethinking how plastic parts are developed — by making injection molding accessible, agile, and local.

Our mission is to **bridge the gap between the idea and industrial production**. With our compact, manually operated injection press — the HoliPress — we offer professionals a powerful tool to prototype plastic parts quickly, accurately, and affordably, without the need for large-scale equipment.

Ideal for product designers, R&D teams, innovation labs, and small-scale manufacturers, the Holipress allows users **to test forms, materials, and functions in real conditions** — accelerating decision-making and **reducing development costs**.

Combined with a range of complementary tools, and material options, Holimaker enables short-run production and rapid iteration — **all within your workspace**.

It's a smart, hands-on approach to innovation, perfectly suited for today's fast-moving industrial environment.



Agenda

HoliPress	3
Complementary products	10
Nozzles	12
Molds	13
Complementary modules	16
Materials	17
Professional services	18

Let's find your perfect fit

Technical characteristics



	HoliPress 16+	HoliPress 38	HP High Temperature
Piston diameter	16 mm	18 mm	
Maximum injection volume	16 cm ³	≈ 34 - 38 cm ³	
Operating temperature	up to 320° C		up to 500° C
Injection pressure at the end of the piston	100 bars	150 bars	
Closing of the mold	Vise, screw, clamp, hydraulic clamping		
Holding pressure	Manual		
Injection speed	2 to 10 seconds		
Mold thickness	10 to 200 mm		
Mold materials	Machined metals and SLA 3D printing		
Adjustable nozzle height	0 to 190 mm		
Production rate	1 pc / 3-6 min		
Electrical power	400W - 220V	860W - 220V	920W - 220V
Type of thermal regulation	PID simple	PID triple	
Weight of the basic pack	29 kg	66.4 kg	74 kg
Heating nozzle	Optional	Simple	Double
Adjustable-length lever	No	Yes	
CE certification	Yes		
Warranty period	12 months		
Compatible polymers	PP, PE, PEHD, PA, TPU, POM, ABS, PELD, PS*		Same as previous + PEEK, PEI, PPS

HoliPress High Temp Starter-Pack

Compact high-temperature machine for challenging materials

Ref: HP38HT

Price ex-VAT: 9 980 €



HoliPress High-Temp is a dedicated manual injection press engineered for processing technical polymers at temperatures of up to 500 °C.

Designed for demanding materials like PEEK and other high-performance plastics, the HoliPress High Temp brings industrial-grade capabilities into a compact, user-friendly machine. Its extended temperature range and robust build provide a reliable solution for material qualification, advanced R&D, small-series production, and specialised training—allowing engineers to process challenging polymers safely and efficiently without relying on a full-scale industrial press.

To be completed with an industrial water chiller featuring a compressor, a minimum flow rate of 13L/min, and a minimum cooling capacity of 1,200 kcal/h. Contact us for more information.

Content of the starter pack

- HoliPress High Temperature
- Triple output temperature control unit
- Clamping vice
- 1 double-heated 5 mm shut-off nozzle
- 1 carabiner machined aluminium test mold
- 1 bag of PEEK granules
- 2 bags of purge granules: standard & high temperature
- 1 cutting pliers
- Cleaning & maintenance accessories
- Individual protective equipment (glasses + high temperature gloves)
- Instruction manual

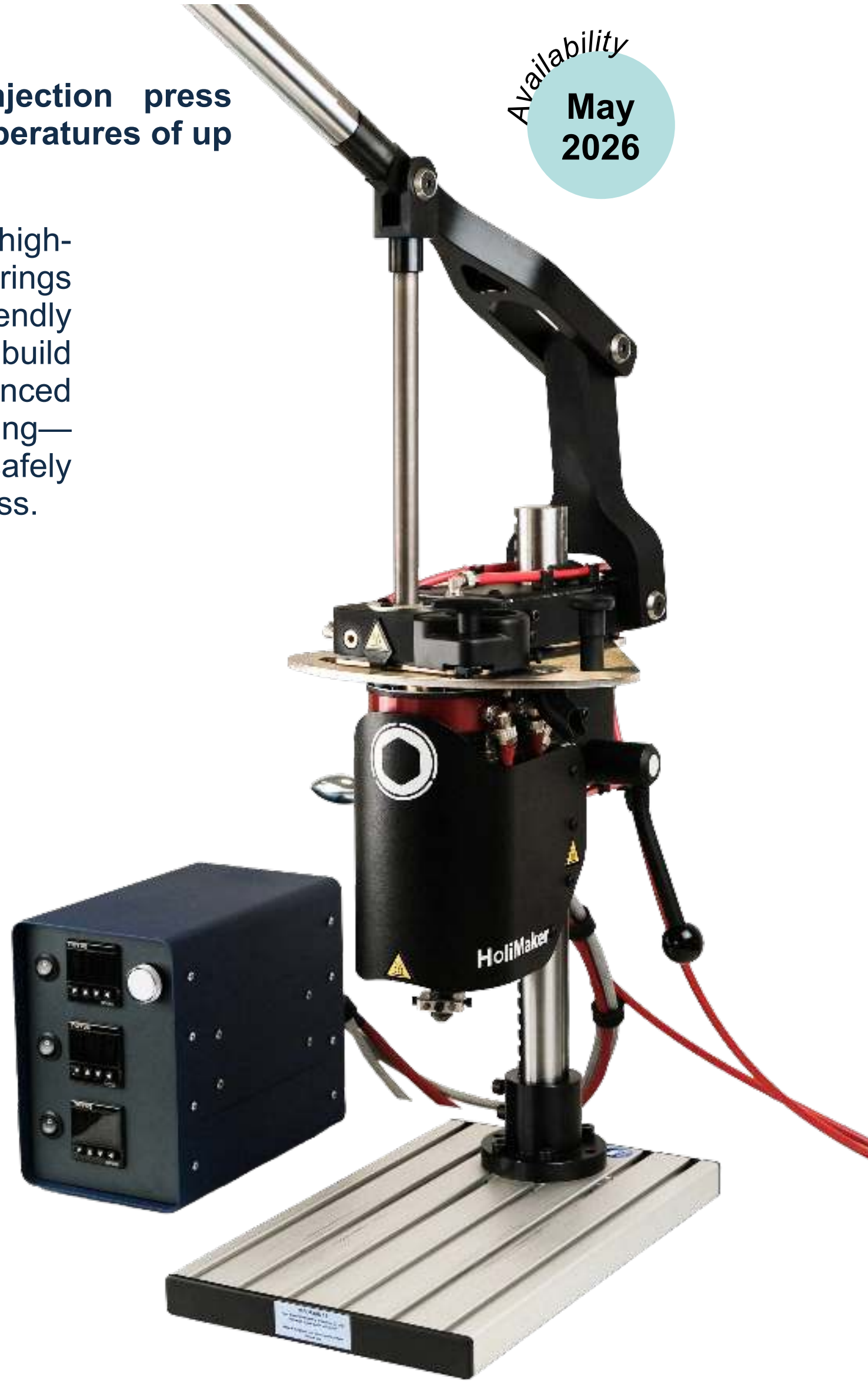

Availability
May 2026



Temperature management box



Clamping vice



5 mm heated shut-off nozzle



Carabiner mold



Cleaning brush



Safety glasses



Pair of thermal gloves



Cutting pliers



Granules bags

High-temperature plastic injection

Designed for advanced engineering plastics, it offers an extended temperature capacity and enhanced thermal control.

It features multiple high-temperature heating zones, a simplified height adjustment system, and an adjustable injection lever for safer, more precise processing of demanding materials.



Integrated cooling system



Limits heat emanation and loss



Easy to use



Easy to clean



Easy feeding of material



Increased safety



Up to 500 °C



Compact by design
240 x 410 x 715 mm



HoliPress 38 Starter-Pack

Large volume injection molding machine



HoliPress 38 is a versatile plastic injection molding solution for prototyping.

It offers a reliable, high-performance option for a wide range of production needs — from research and development and prototype creation to small-series production and plastics processing training.

Content of the starter pack

- HoliPress 38
- Triple output temperature control unit
- Clamping vice
- 1 heated 5 mm shut-off nozzle
- 1 machined aluminium test mold
- 1 bag of recycled PP granules
- 1 bag of food-grade natural PP granules
- 1 cutting pliers
- Cleaning & maintenance accessories
- Individual protective equipment (glasses + gloves)
- Instruction manual

Ref: HP38PACK
Price ex-VAT: 6 980 €

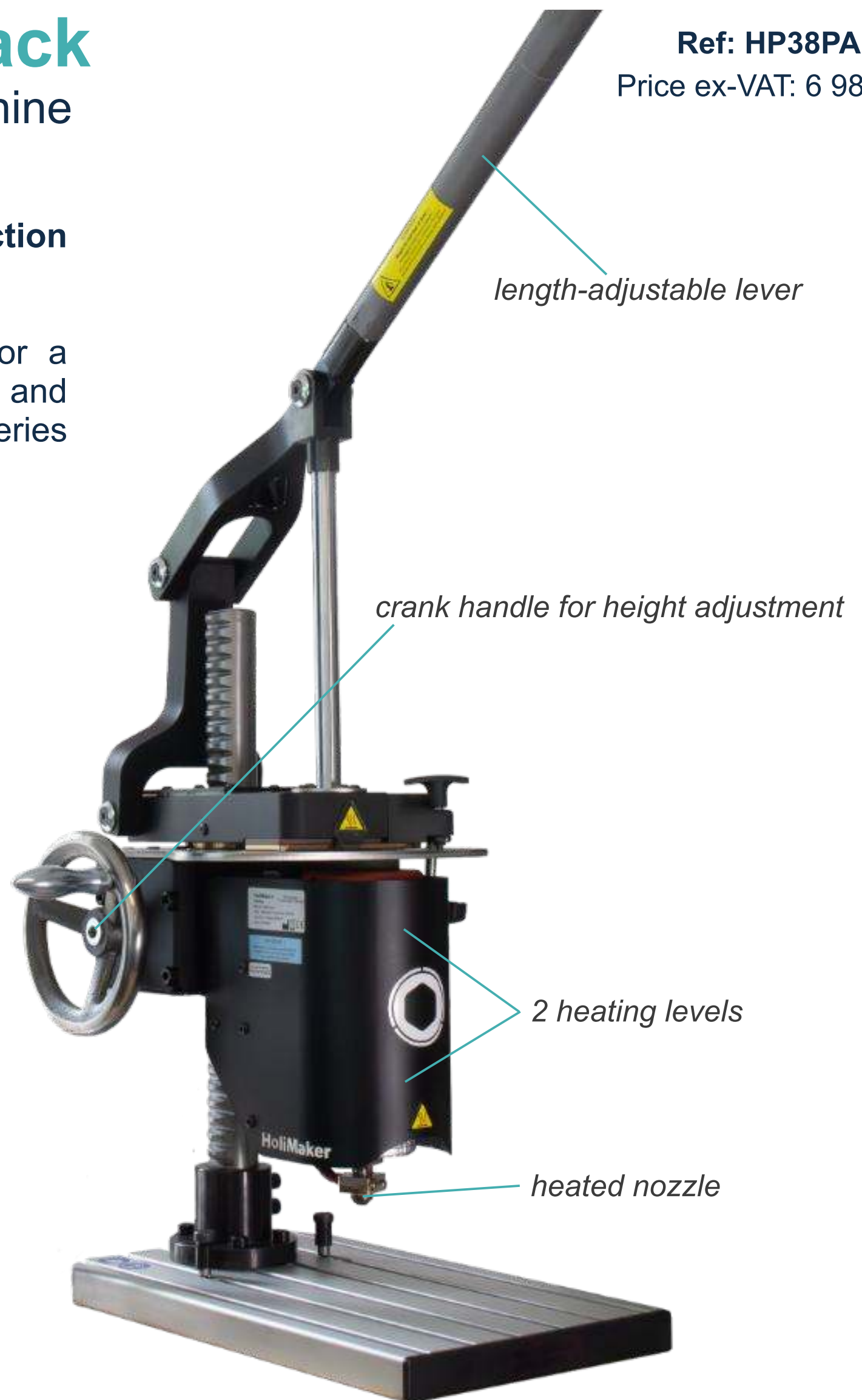

Temperature management box



Clamping vice



5 mm heated shut-off nozzle



Carabiner mold



Cleaning brush



Safety glasses



Pair of thermal gloves



Cutting pliers



Granules bags

Dimensions

HoliPress 38

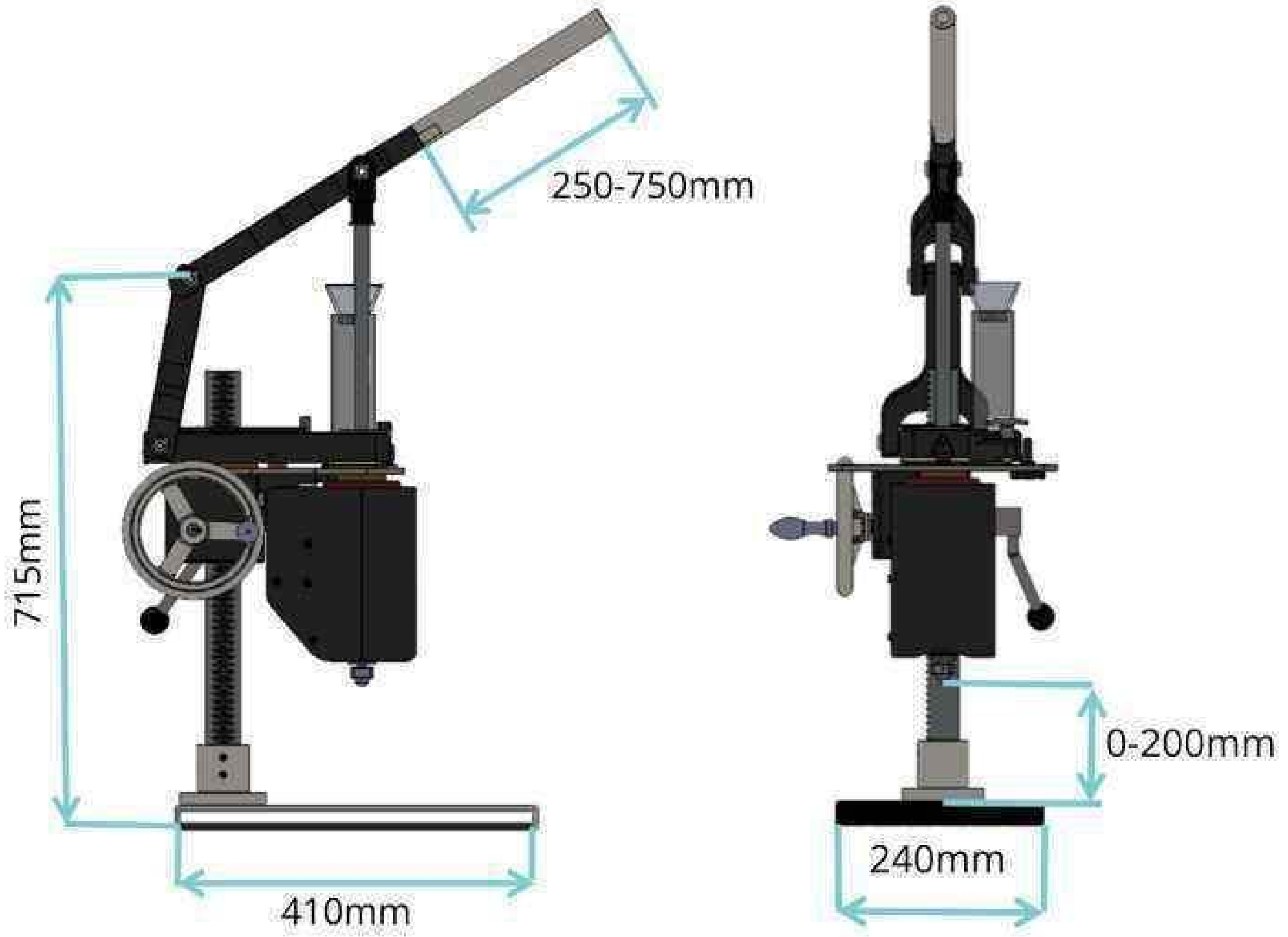

HoliPress 16+

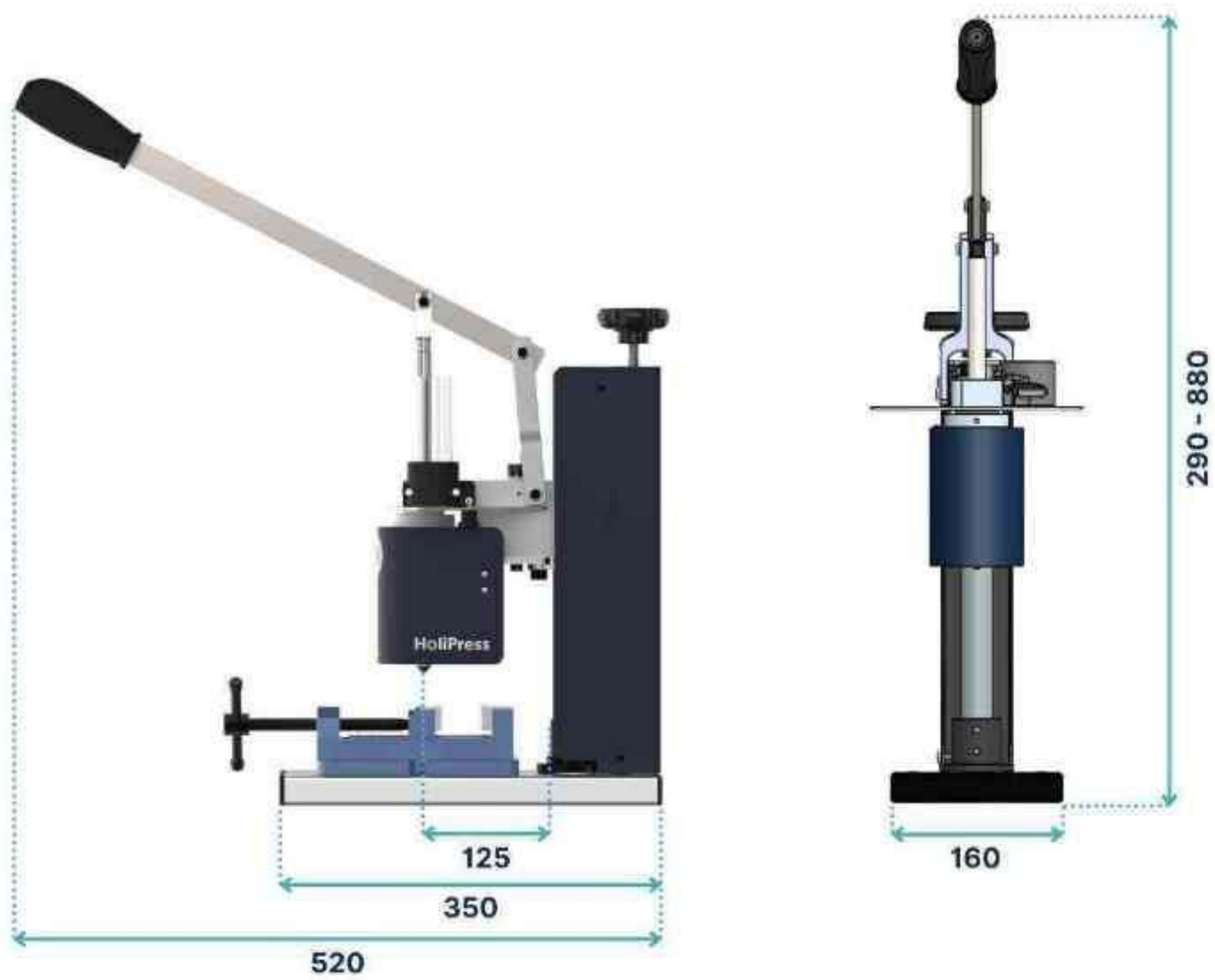

HoliPress 16+ Starter-Pack

Produce your plastic injection parts independently



HoliPress 16+ allows you to manually inject plastic parts using standard industrial raw materials.

Its compact design and ease of use enable you to produce plastic prototypes in record time. An ergonomic handle and a turn-wheel knob attached to the column rack allow for easy adjustment of the nozzle height.

Content of the starter pack

- HoliPress 16+
- Temperature management box
- Clamping vice
- 3 mm shut-off nozzle + purge block
- 3 mm standard nozzle
- Machined aluminium spinner test mold
- 1 bag of PP recycled granules
- 1 bag of natural food grade PP granules
- Cleaning and maintenance accessories
- Individual protective equipment (1 pair of glasses + 1 pair of gloves)
- Instruction manual

Ref: HP16PACK+
Price ex-VAT: 2 990 €



Temperature management box



Clamping vice



3 mm shut-off nozzle
3 mm standard nozzle
Purge block



Spinner test mold



Cleaning brush



Safety glasses



Pair of thermal gloves



Cutting pliers



Granules bags

Hydraulic mold clamping system

Modular system for flexible, high-efficiency molding

This 2-column (or 4-column) system is designed to clamp an injection mold for greater efficiency and faster handling. Its versatile design allows for both horizontal injection (into the parting line) and vertical injection (into the mass).



Ref: HPC014

Price ex-VAT: 1 250 €

Hydraulic clamp

Engineered for precision, built for flexibility

Hydraulic clamping system designed to securely hold injection molds for efficient and precise operations. Sold without pump or hydraulic connector (optional: HPC015). Compensating shims allow precise adjustment for various mold thicknesses.

Fits HoliPress 16+, 38, and High temperature.

Maximum mold dimensions: 165 × 115 × 70 mm.

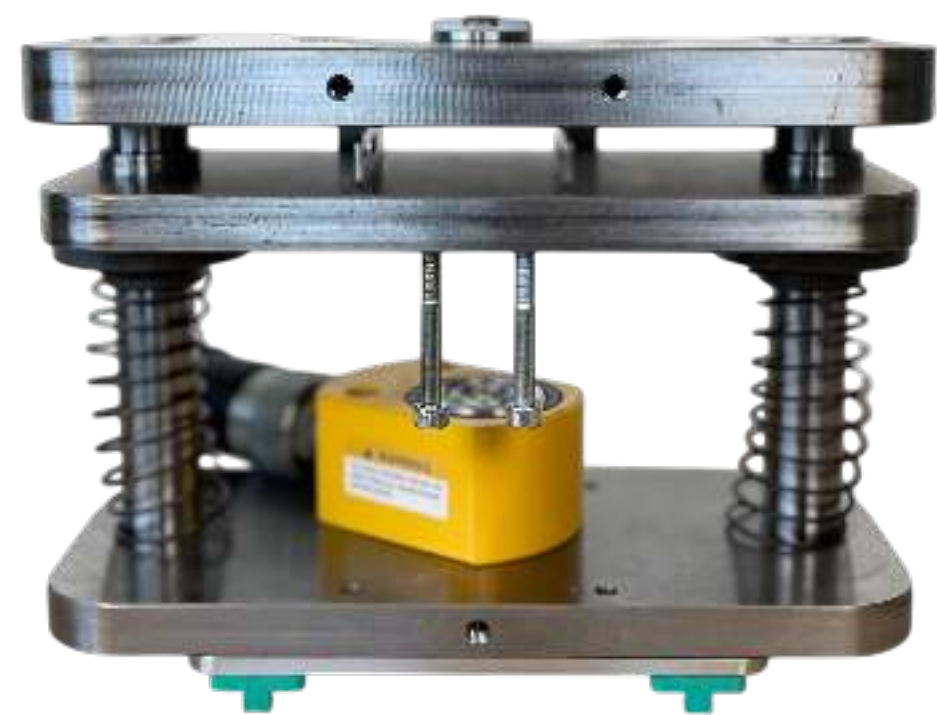

Also available in a 4-column version for higher molds. Recommended for tensile specimen molds. Maximum mold dimensions: 110 x 185 x 70 mm.

Ref. HPC016

Price ex-VAT: 1 650 €

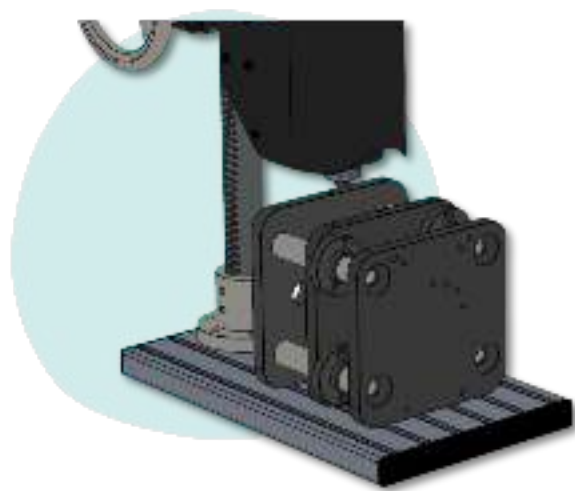

Horizontal position for injection in the parting line

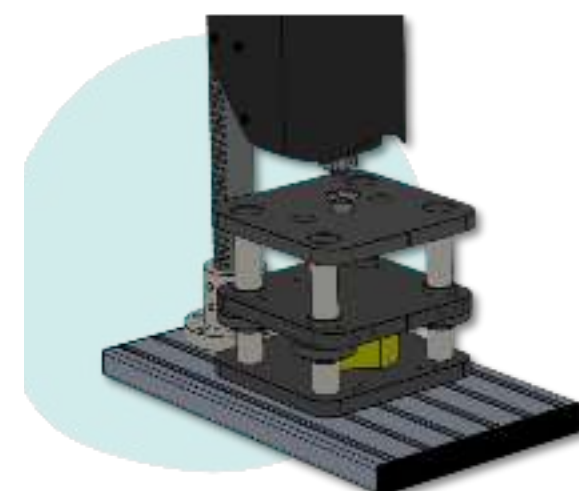
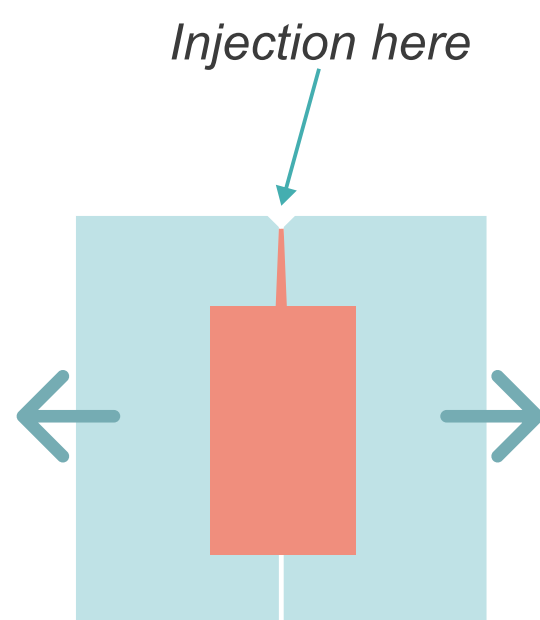

Vertical position for injection into the mass

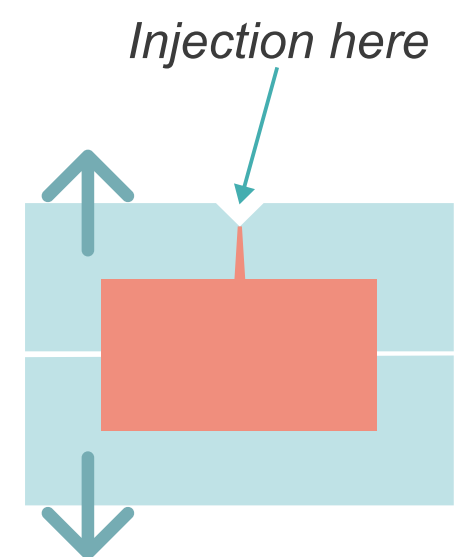

Hydraulic plump

Plug, pump, and press with precision

Hydraulic pump supplied with pressure gauge and connectors.

Delivered with 1L of hydraulic oil.



Ref: HPC015

Price ex-VAT: 790 €

HoliShred

Manual shredder to grind plastic materials into flakes

Ref: HS

Price ex-VAT: 1 350 €



HoliShred is an innovative tool designed to grind plastic materials into flakes, ready for use in the HoliPress.

Equipped with a pusher, HoliShred safely blocks plastic waste and prevents access to the grinding blades.

It also features a collection tray to gather the shredded flakes.

Finally, three sturdy levers make shredding plastic waste easy and efficient.

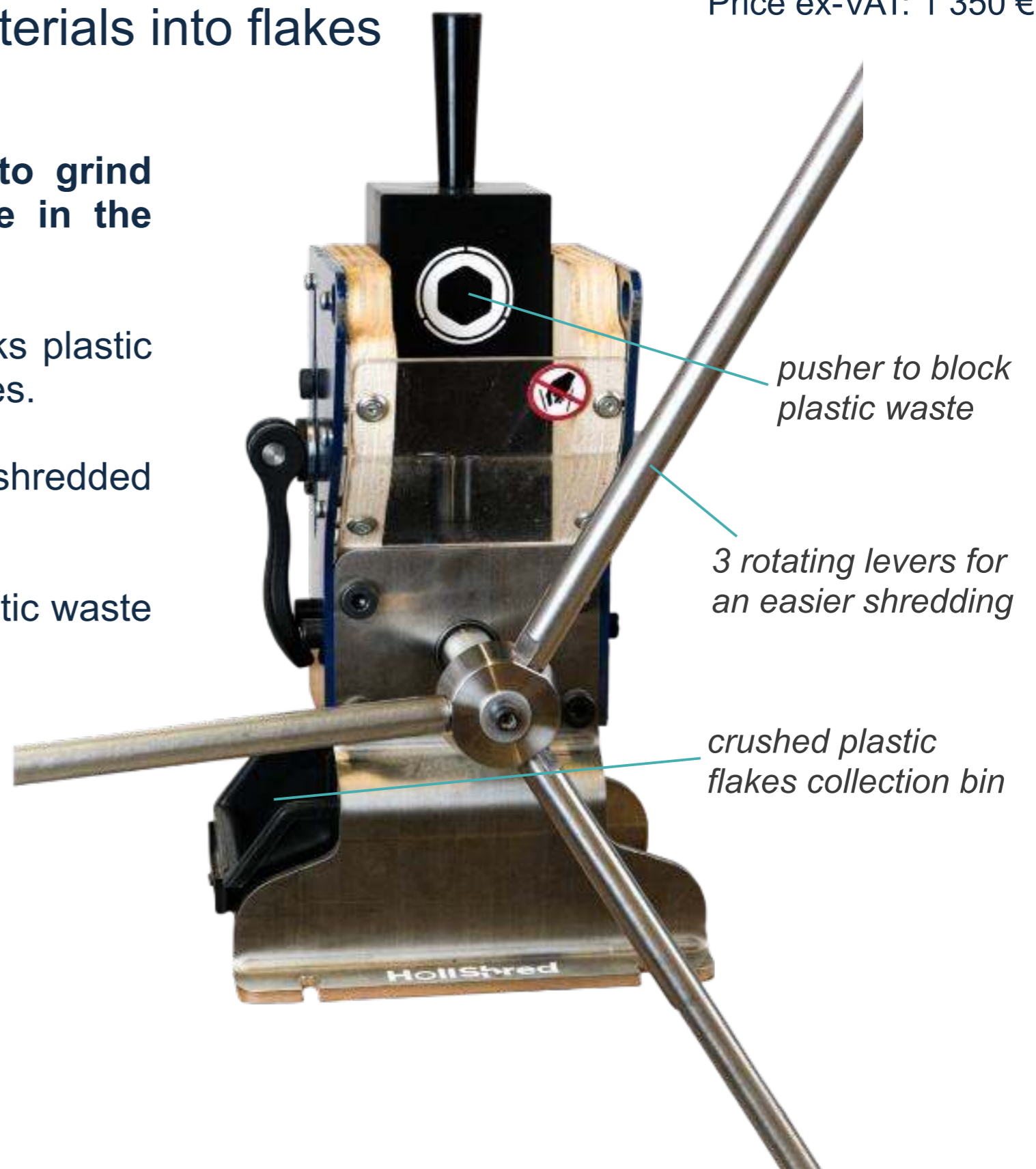

HoliDesk

The perfect workstation for HoliMaker machines

Ref: HD

Price ex-VAT: 500 €

The HoliDesk is a robust workshop table designed specifically for mounting the **HoliShred** manual plastic shredder and the **HoliPress 16 or 38** manual injection molding machines.

Built with a thick wooden top for stability and durability, it also features a **convenient drawer** for storing injection molds and HoliMaker accessories.

This sturdy, purpose-built furniture provides an **ideal setup for using the HoliPress** in any workshop environment.

Dimensions:

73 cm (L) x 70 cm (W) x 89 cm (H)

Weight: 48 kg

*Presentation image featuring:
HoliShred and HoliPress 16*

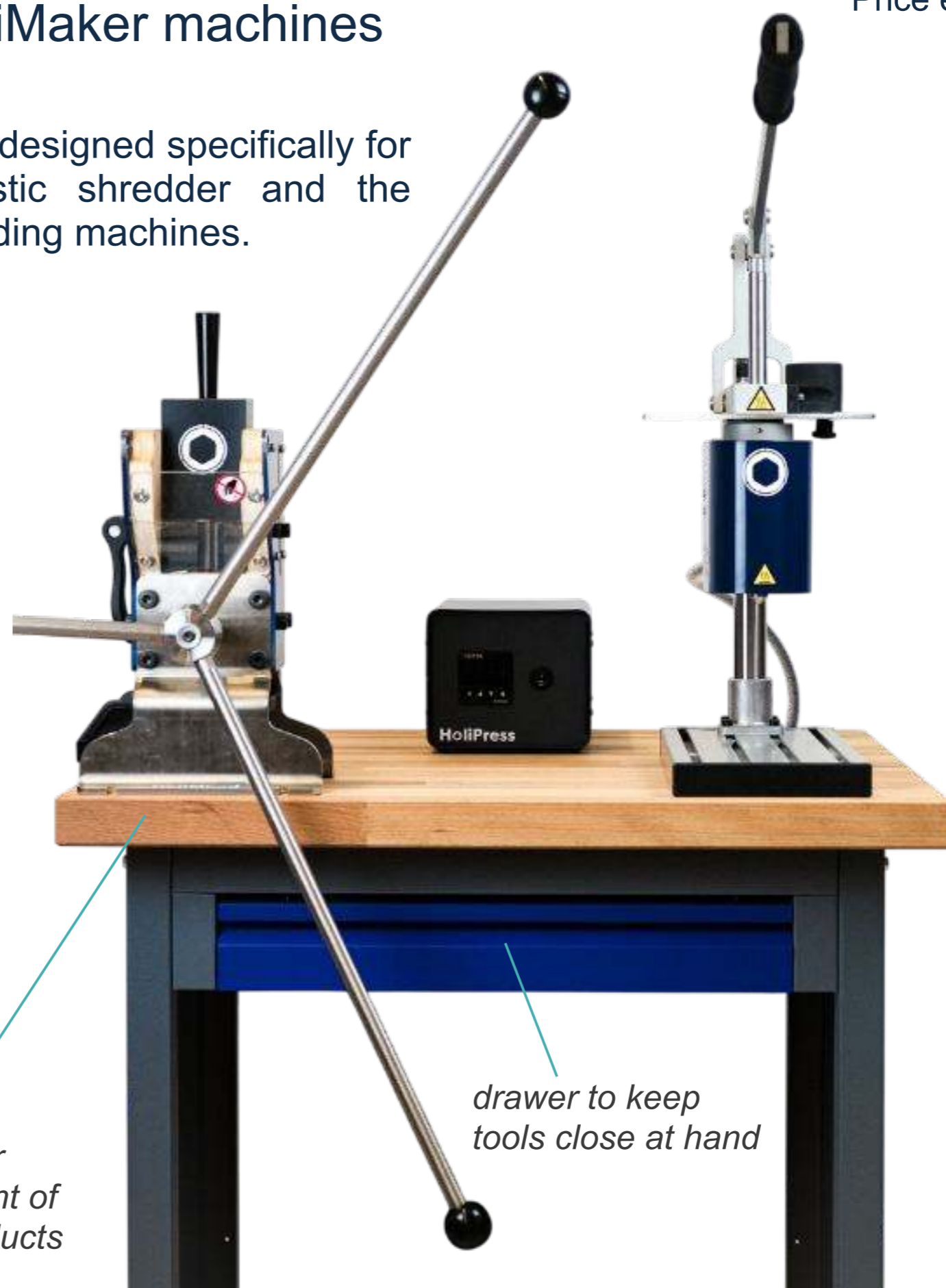

HoliCase

Secure, reinforced transport for your HoliMaker equipment

Ref: HC

Price ex-VAT: 1 200 €

The HoliCase is a reinforced flight case engineered to protect and transport HoliMaker machines with complete confidence. Designed by our engineers for durability, it features a robust structure and heavy-duty castors for smooth mobility at schools, workshops, trade fairs, or exhibitions.

Its interior layout is optimized to securely hold the HoliPress 16 or 38, HP38HT manual injection molding machine, the HoliShred manual plastic shredder, the fume filtration system, and additional equipment such as injection molds, tools, or even a display banner.

Dimensions: 92 cm (L) × 62 cm (W) × 96 cm (H)

Weight: 45 kg

Presentation image featuring: fume filtration, HoliPress 16 and HoliShred

Customizable front panel (70x35cm) - option 200€



Preheating system with cartridges

Mold or nozzle temperature for precise, high-quality injections

Ref: HPC08

Price ex-VAT: 480 €



The preheating system is designed to maintain machined aluminum injection molds at a stable, controlled temperature. This allows for easier injection of thin-walled parts and technical materials, improving part quality and process reliability.

The system powers up to **two included 65 W heating cartridges**, ensuring efficient and uniform heat distribution.

It can be used either to heat a mold with the supplied cartridges or to power a heating nozzle.

A temperature sensor is included for precise control.

Specifications:

- Input: 220 V AC – 6 A
- Output: 2 × 24 V DC – 3 A

heating cartridges



Also available in a dual configuration (2x65W) for enhanced heating performance.

Ref: HPC017
Price ex-VAT: 650 €

Shut-off & standard nozzles

Controlled flow for efficient plastic injection

The shut-off nozzle is supplied with the HoliPress and retains the plastic in the heating chamber to ensure efficient plasticization.

The standard nozzle (not supplied with HP38) is ideal for injecting high-viscosity plastics.

Nozzle	Press	Ref.	Price ex-VAT
Shut-off 5 mm	HP16	HPM015	170 €
Standard 5 mm	HP16	HPM016	100 €
Shut-off 3 mm	HP16	HPM017	170 €
Standard 3 mm	HP16	HPM018	100 €
Shut-off 5 mm	HP38	HPM021	170 €
Standard 5 mm	HP38	HPM022	100 €
Shut-off 3 mm	HP38	HPM023	170 €
Standard 3 mm	HP38	HPM024	100 €



5 mm shut-off nozzle



3 mm shut-off nozzle



5 mm standard nozzle



3 mm standard nozzle

Heated shut-off nozzles

Maintaining the temperature right up to the mold

The heated shut-off nozzle is made of stainless steel and thermoregulated by a 24V heating cartridge.

This nozzle is ideal for injecting fast-cooling plastics such as polyamide or polyester.

- For HP38 - ref. HPM019 - Price ex-VAT: 380 €
- For HP16+* - ref. HPM020 - Price ex-VAT: 380 €
- For HP38HT - ref. HPM025 - Price ex-VAT: 580 €

*HP16+ 5 mm heated shut-off nozzle (Ref. HPM020) must be used with either the HPC08-02 (heating control unit 130W) or the HPC08 (preheating system).



heated nozzle for HP16+ & HP38

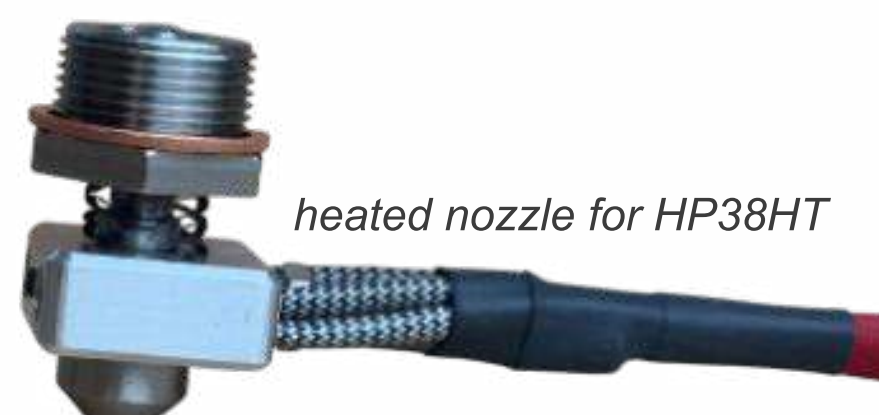

heated nozzle for HP38HT

Tensile specimen mold - 1A

For mechanical testing and material evaluation

Ref: HPC013

Price ex-VAT: 390 €

Standard aluminium mold for making tensile test samples based on **ISO 527-2 type 1A**.

Can be combined with a pre-heating system (ref. HPC08 or HPC017) for improved injection performance.

Closure with screws, but the 4-column hydraulic clamping system can also be used.



Tensile specimen mold - 1B

For mechanical testing and material evaluation

Ref: HPC010

Price ex-VAT: 180 €

Standard aluminium mold for making tensile test samples based on **ISO 527-2 type 1B**.

Can be combined with a pre-heating system (ref. HPC08 or HPC017) for improved injection performance.

Closure with a clamping vice (providing with HoliPress starter packs).



Rectangular bar specimen mold

For bending and impact evaluation

Ref: HPC018

Price ex-VAT: 450 €

Standard aluminium mold for making rectangular bar specimen test samples based on **ISO 178**.

Can be combined with a pre-heating system (ref. HPC08 or HPC017) for improved injection performance.

Closure with screws, but the 4-column hydraulic clamping system can also be used.



Rheology specimen mold

Reliable mold for material flow testing

Ref: HPC012

Price ex-VAT: 450 €

Aluminum mold designed for injection rheology tests.

Dimensions: 30 mm (d) x 2 mm (T)

Can be combined with a pre-heating system (ref. HPC08) for improved injection performance.

Closure with a clamping vice, but the 2-column hydraulic clamping system can also be used.



Staircase mold

Designed for precise thickness testing

Ref: HPC040

Price ex-VAT: 450 €

Aluminum mold designed for injecting staircase specimens for thickness tests and customer samples.

Dimensions: 70 mm / 40 mm

Injected molding thickness:
3 mm / 2 mm / 1 mm

Can be combined with a pre-heating system (ref. HPC08 or HPC017) for improved injection performance.



Carabiner mold

Ref: HPC042

Price ex-VAT: 150 €



Custom spinner mold

Ref: HPA07

Price ex-VAT: 240 €



Customization: 25 characters maximum

Custom bottle opener mold

Overmolding and customisation

Ref: HPC043

Price ex-VAT: 400 €

Aluminum mold designed for injecting custom bottle openers.

The mold is customizable on both sides with 3D resin inserts and comes with 100 metal bottle opener inserts.

Can be combined with a pre-heating system (ref. HPC08 or HPC017) for improved injection performance.



Metal inserts for bottle opener mold.
Ref. HPC044

Aluminium reinforcements for 3D printing molds

Reinforcing 3D printed Molds for strength and longevity

Precision-machined aluminum frames designed to strengthen 3D-printed molds or combine with cast epoxy resin for durable hybrid molds.

They ensure stability, reliability, and repeatable results in small-scale injection.

2 available sizes (internal mold dimensions):

- 100 mm / 60 mm / 30 mm
ref. HPC02 - Price ex-VAT: 350 €
- 60 mm / 60 mm / 30 mm
ref. HPC03 - Price ex-VAT: 120 €

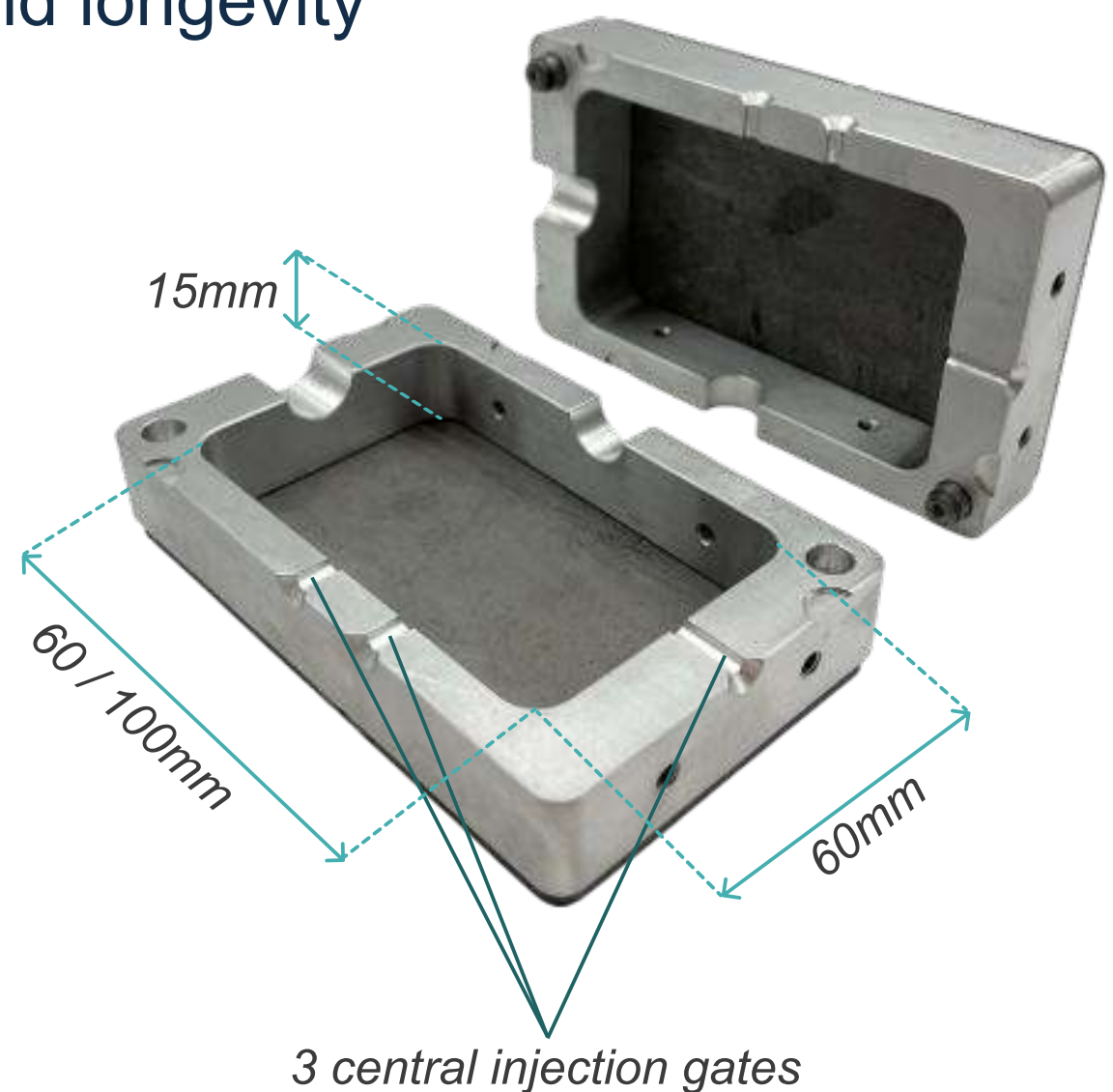

Water-cooling system

To pair with HoliPress High Temp

Ref: HPA01

Price ex-VAT: 650 €

Professional-grade cooling system equipped with a high-performance compressor and flow management.

Designed to provide thermal stability and consistent performance for your industrial processes.

- Power Supply: 220V-50Hz / 2.4~3.3A
- Cooling Capacity: 1.73 kW
- Compressor Power: 0.5 kW
- Precision: $\pm 2^{\circ}\text{C}$
- Flow Rate: 13L/min
- Refrigerant: R410A
- Dimensions: 56 x 29 x 49 cm



Fume filtration system

Safe plastic injection by capturing fumes directly at the source

Ref: HPC09

Price ex-VAT: 1 600 €



It consists of a high-performance vacuum unit, two flexible extraction arms, and collection nozzles positioned close to the HoliPress for maximum efficiency.

Equipped with a BOFA® multi-stage filter, the system provides thorough protection:

- **Pre-filter** traps larger particles
- **HEPA filter** removes fine particulates
- **Chemical gas filter** neutralizes harmful fumes

This professional-grade solution keeps your workspace clean, safe, and compliant with best practices for plastics processing.

Once worn, you can replace the filter:
ref. RSFM / Price ex-VAT: 290€



Also available with 1 extraction arm.
Suitable to vacuum fumes from the heating chamber or out of the nozzle.

Ref. HPC06
Price ex-VAT: 1 200 €

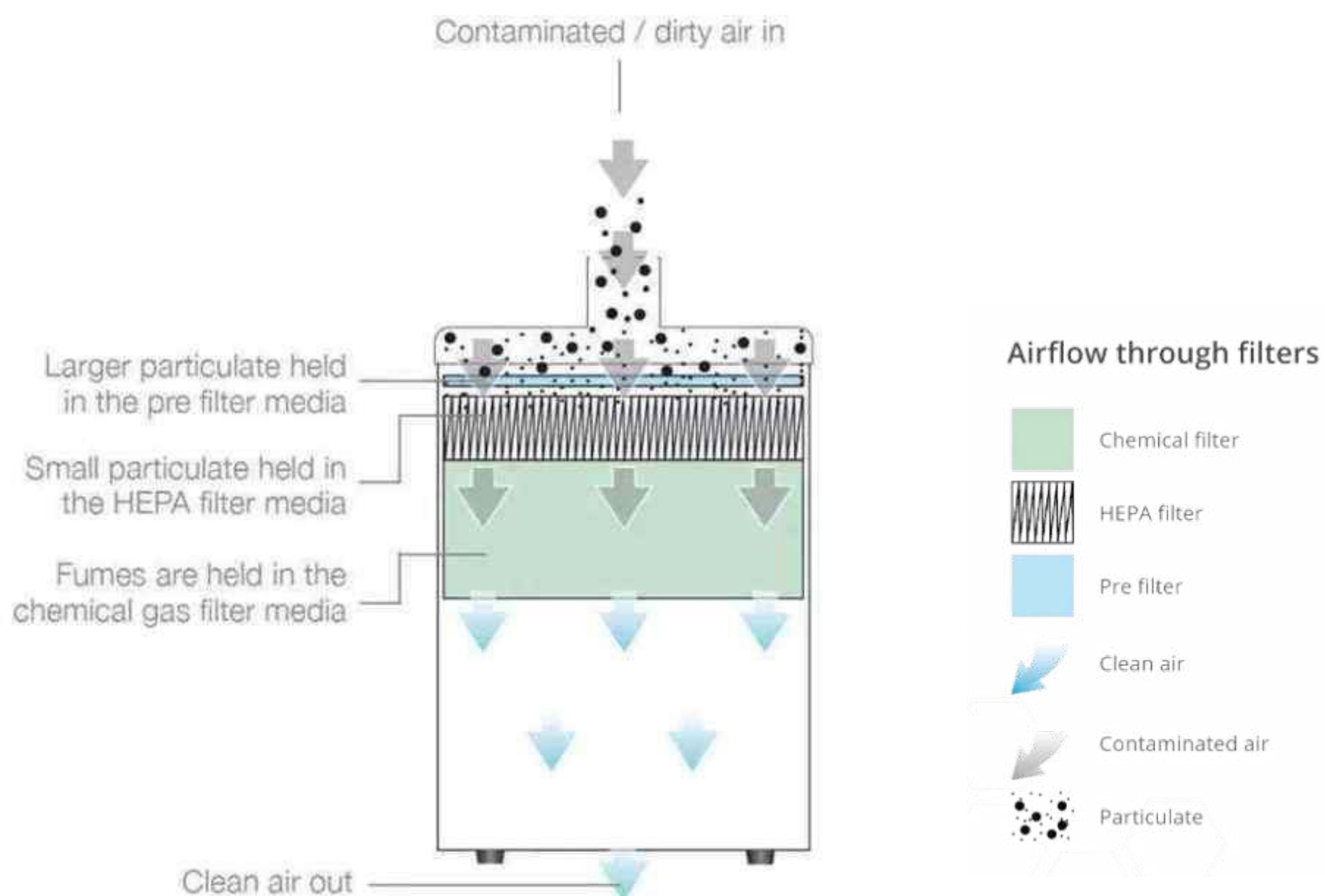

Our machines can process most thermoplastics. Here are some reference materials we offer for resale:

Materials	Ref.	Price ex-VAT
Granules assortment 4 x 0,25kg Assortment of pellets for testing injection with HoliPress	HPC020	32 €
Food grade PP granules 0,5kg Suitable for food contact > Natural white - ISPLEN BP180 G2M	HPC021	9,50 €
Regenerated PP granules 0,5kg GLOBAL RECOV > Black > Orange	HPC022 HPC046	7 € 8 €
POM granules 0,5kg > Natural white - SABIC 90S	HPC023	14,50 €
PA6 granules with 30% GF 0,5kg > Natural - AKULON K224-G6 – DSM	HPC058	22,50 €
PA6 granules with 15% GF 0,5kg > Natural white - DOMAMID 6G15 PA6	HPC024	14,50 €
PA6.6 granules 0,5kg > Black - DSM F223D	HPC047	22,50 €
SEBS shore 45A granules 0,5kg > Natural white - ENPLAST Ensoft SO-161-45A	HPC025	12,50 €
SEBS shore 90A granules 0,5kg > White - ENPLAST Ensoft SO-161-90A	HPC026	12,50 €
PEHD granules 0,5kg > Natural white - SIBUR 85612 IM	HPC039	12,50 €
PELD granules 0,5kg > Natural white - RIBLENE MP31R	HPC048	12,50 €
PP granules with 30% GF 0,5kg > Black - RAVAGO - MAFILL CR XG 5544 > Natural white - SIRMAX - ISOGLASS 14014	HPC049 HPC030	12,50 € 12,50 €
ABS granules 0,5kg > Natural white - LG CHEM - ER460 > Gray - CHIMEI - Polylac PA-717C	HPC036 HPC057	11,50 € 14,50 €
HIPS granules 0,5kg > Natural white - KUMHO - HI425	HPC050	12,50 €
ASA granules 0,5kg > Natural white - LG CHEM - LI918	HPC051	12,50 €
TPE granules 0,5kg > Translucent white - KRAIBURG TM7LFT_S102 > Black - KRAIBURG TC7GPZ_B100	HPC052 HPC054	22,50 € 24 €
PEEK granules 0,5kg > Natural - VESTAKEEP 2000 G	HPC055	90 €
Purge granules 0,5kg > Regular temperatures > Ultra Purge HT+ - high-temperature	HPC045 HPC056	22,50 € 22,50 €

This list is not exhaustive of all materials compatible with the HoliPress. Don't see the desired material listed? No problem — just contact us.

Feasibility study

From design to injection — assess your part's viability

Ref: HMS04

Price ex-VAT: on request

This service is intended for companies looking to determine whether their parts can be injected using the HoliPress.

The feasibility study includes the design of a test mold, 3D printing of a Formlabs resin mold, injection testing with the desired material, and delivery of the produced parts.



Material testing

Validate your material before production

Ref: HMS07

Price ex-VAT: on request

This service is intended for companies evaluating a material for injection with the HoliPress.

The material test includes the injection of a staircase test piece and a tensile test piece, both using machined aluminium Molds. The test specimens are delivered to you along with our observations on injectability.



Resin mold printing

Prototype your parts with custom 3D printed tooling

Ref: HMS03

Price ex-VAT: on request

This service is designed for companies and innovators who need to validate a part's geometry and material compatibility without metal tooling.

Simply provide a STEP file of your part, and we will design and 3D print a high-precision resin mold compatible with the HoliPress. This solution is ideal for rapid prototyping, allowing you to test specific shapes and run your own material trials in-house. You receive the ready-to-use resin mold, empowering you to iterate quickly and refine your design before moving to final production.



✓ Prototyping: Produce high-quality parts quickly and affordably.

With HoliPress, you can reduce costs, accelerate prototyping, and bring better products to market faster. It's designed to produce clean, final-quality parts for a wide range of applications.

✓ Recycling: Easily recycle your plastic parts with HoliMaker solutions.

With HoliShred, you can process sprues, runners, and failed parts into reusable granulate. It is the essential step for any professional looking to implement a circular and sustainable injection workflow.

Notes

HoliMaker[®]

HoliMaker supports you throughout your projects.

We offer training in 3D design for plastic injection Molds using the HoliPress, as well as training in part design for injection molding.

HoliMaker also provides a small-batch production service for injected parts prior to mass production.



Prototyping



Material testing



Recycling



Small series



332 rue Lieutenant Colonel
Dagnaux - 57685 AUGNY - FR

commercial@holimaker.fr

www.holimaker.fr

